

INVENTORY OF PARTS

- | | |
|---------------------|----------------------|
| CHAIR PARTS: | 1 BUFFER TOOL |
| 2 SEATS | |
| 2 BACKS | |
| 2 BOTTOM RACKS | TABLE PARTS: |
| 2 BOTTOM RUNGS | 1 TABLE TOP |
| 2 RIGHT SIDES | 4 LEG END CAPS |
| 2 LEFT SIDES | 4 LEGS |

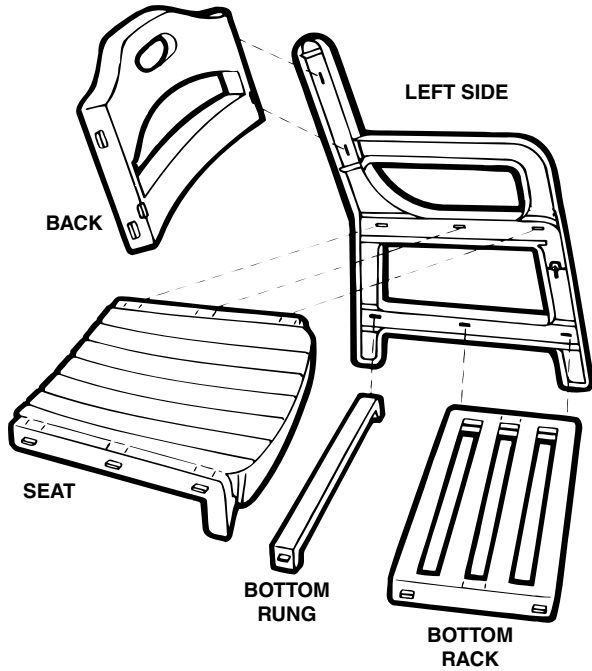

- Begin assembly by placing left side (piece marked 'inner left side') on a hard flat surface. 'Inner left side' type should be facing up. Place back, seat, bottom rack and rung into slots on left side piece as shown. Seat corner must first be pushed into a special slot before other slots are tapped together (illustration A).
- Align piece assembled in step 3 to right side (piece marked 'inner right side') and tap together. You now should have an assembled chair. Repeat steps for second chair. Inspect to make sure both chairs feel solid and all snaps are locked.

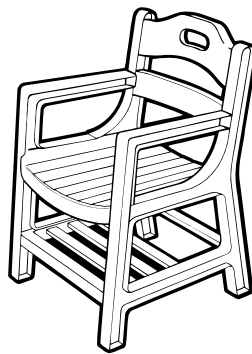

DIRECTIONS

- CHECK TO SEE IF YOU HAVE ALL OF THE PARTS DESCRIBED IN THE PARTS LIST
- ADULT ASSEMBLY IS REQUIRED
- HAMMER IS NEEDED

CHAIR ASSEMBLY:

- Note that the basic method of attachment for the chair is to pass a notched, rectangular extension through a slot until the notch locks into place. Use the buffer tool (supplied) and hammer to tap the extension through the slot **until it locks**. (Buffer tool helps prevent hammer from damaging chair. For safety, dispose of tool after assembly.)
- Remember there are parts for two chairs. It may be easier to first separate the parts into two piles. There shouldn't be two of the same part in a pile.

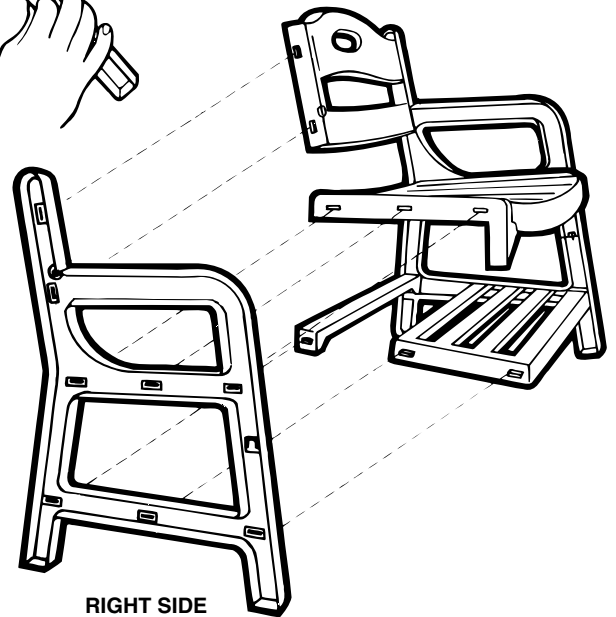
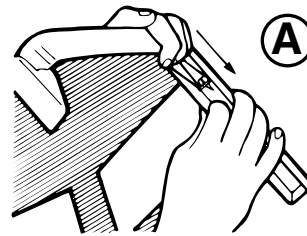
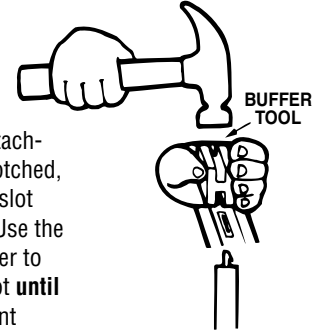

TABLE ASSEMBLY:

- Push one end cap into one end of each of the 4 legs.
- Push leg assembly into holes on bottom of table top as shown.

